

Z 27.14

89' WORKING HEIGHT

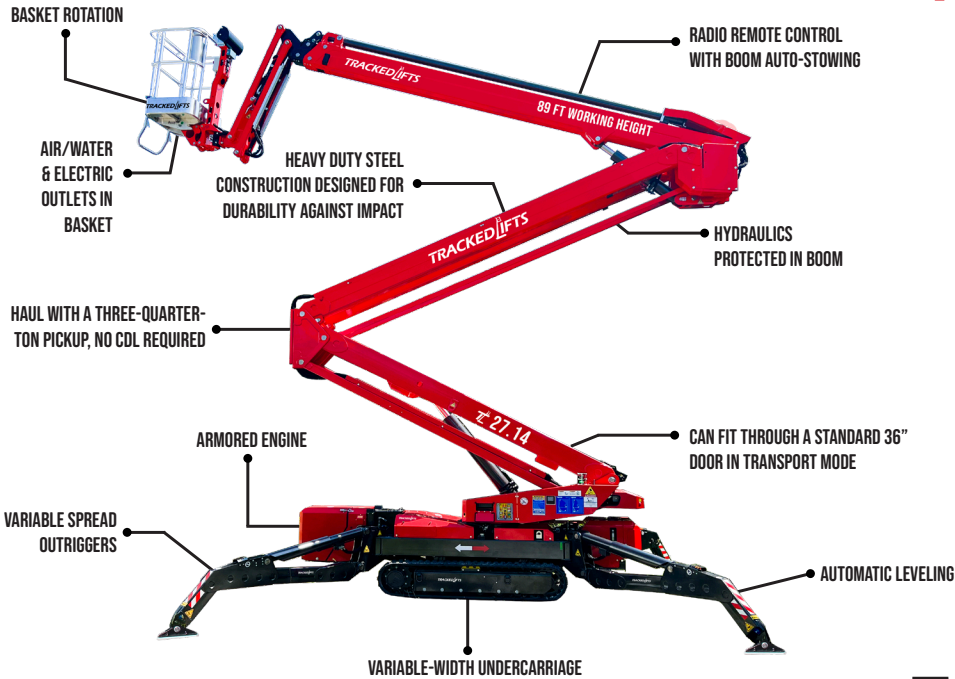

SPECIFICATIONS

Max. working height	89'
Max. outreach	50'
Max. basket load	300 lbs
Basket size	2'7" x 2'3" (1-man basket)
Basket rotation	± 90°
Turret rotation	360° non-continuous
Traveling length	20'7" (23'3" with basket)
Traveling height	6'6"
Traveling width	35" narrow mode / 51" wide mode
Outrigger Spread	15'6" x 17'2" wide position / 11'5" x 21' narrow position
Battery	12V Emergency Descent System
Diesel Engine	Kubota Diesel, 22 HP
Total weight	11,500 lbs
Gradability, max. across slope	31% (17°)
Gradability, max. up and down slope	31% (17°)
Deployment ability on slopes up to	31% (17°)

DIAGRAMS

DATA AND DIMENSIONS ARE INDICATIVE AND NOT BINDING

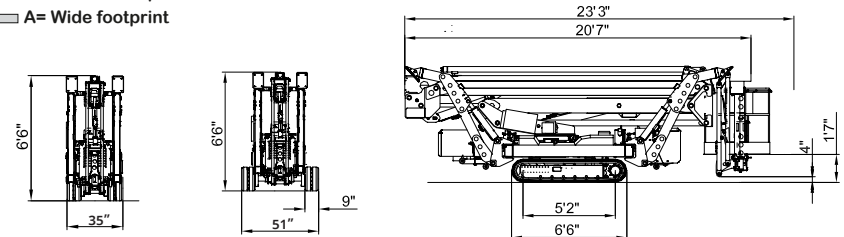
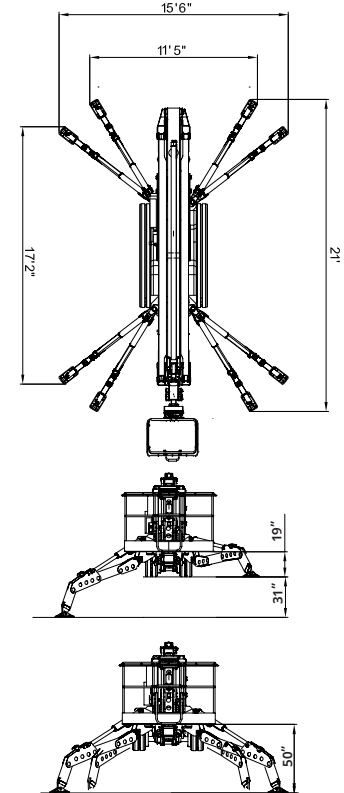
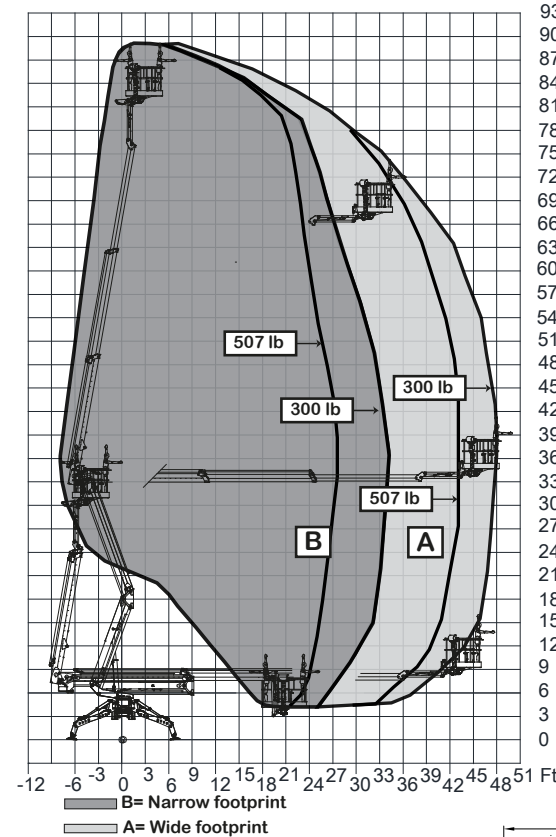

ADD-ON OPTIONS:

- White Rubber Non-Marking Tracks
- Custom Colors
- 2-man Basket
- Hybrid 24V Lithium Battery Pack
- Wind Gauge to Monitor Max Wind Speed
- Intercom
- Basket Light